

# PERFORMANCE OF INTEGRATED R744 PACKS PART 2 - EJECTORS PERFORMANCE, A COMPARISON OF DATA-DRIVEN MODEL FROM ONSITE MEASUREMENTS WITH ROM MODEL PREDICTIONS

Vahid Khorshidi<sup>(a)</sup>, Ekaterini E. Kriezī<sup>(a)</sup>, Christian Schlemminger<sup>(b)</sup>, Armin Hafner<sup>(b)</sup>

<sup>(a)</sup> RAC R&D Danfoss A/S -Nordborgvej 81, 6430 Nordborg, Denmark, [vk@danfoss.com](mailto:vk@danfoss.com) & [ek@danfoss.com](mailto:ek@danfoss.com)

<sup>(b)</sup> SINTEF Energy Research, Kolbjørn Hejes vei 1 D, 7034 Trondheim, [christian.schlemminger@sintef.no](mailto:christian.schlemminger@sintef.no)

<sup>(c)</sup> NTNU, Trondheim Norway, [armin.hafner@ntnu.no](mailto:armin.hafner@ntnu.no) & [engin.soylemez@ntnu.no](mailto:engin.soylemez@ntnu.no)

## ABSTRACT

Rising concerns for climate change impacts along with the new legislation aimed at lowering emissions indicates the inevitable transition in the cooling/heating industry towards a more energy-efficient solution with minimal environmental impact. Integrated refrigeration, air condition and heat recovery solutions by CO<sub>2</sub>(R744) packs are efficient solutions to high energy demanding building (supermarkets and hotels). Proven performance enhancement of Multi Ejector Solution™ makes the R744 systems more energy efficient, especially in warm climates, compared to the most conventional synthetic refrigerant systems in food retail applications.

Pilot installation in the frame of MultiPack, an EU funded project(Horizon 2020), provided a wide range of data, offering the possibility of evaluating the real performance of each ejector group: high pressure (HP), low pressure (LP), and liquid ejector(LE), by running the system in different operating modes. Analysis of the data indicated performance improvement of a system with ejector, on average a 35% lower energy consumption compared to baseline parallel compression R744 system without ejectors.

The availability of mass flow measurement from 5 Coriolis mass flow meters on this pilot, enabled the possibility of comparison of mass flow rate in different evaporation temperatures. Data-driven models were used to estimate the performance of ejectors (Entrainment ratio) using onsite data from various operating modes and compare them with the simulated performance from CFD and lab measurements. Careful data pre-processing allows the data-driven model to predict the ejector performance using compressor mass flow rate models trained based on no ejector mode data derived from onsite measurements and compare with models validated by highly accurate lab experiments.

Keywords: R744 (CO<sub>2</sub>); Ejectors, Compressors, Integrated systems, Refrigeration, Data-driven models, Energy saving

## 1. INTRODUCTION

The MultiEjector™ is still an emerging technology in CO<sub>2</sub> system. The ejector block in the market has matured significantly both in the system design and the control strategy. In the last five years, there have been a lot of laboratory and simulation studies conducted regarding the performance of individual ejector cartridges in a controlled environment. The studies have resulted in a model that can predict the performance of the component at a defined operational envelop(Haida 2018, 2019, and 2020).

In real supermarket installations, there are some losses and uncertainties impact the performance of the MultiEjector™, hence it is important to monitor and investigate the components' performance. For accurate monitoring and analysis of the components, detail instrumentation with mass flow meters, pressure, and temperature sensors in all inputs and outputs is required. The detailed instrumentation is not applicable in real installations, hence another method of estimating the performance should be used, utilizing the already available data from the system measurements.

The paper presents, the estimation of the MultiEjector™ performance in a supermarket, based on the compressor mass flow rates from a trained data -driven method, (refer to part 1) and the comparison with the existing performance function based on operational conditions. The pilot installation used in the paper is in the frame of MultiPack, an EU funded project.

## 2. SYSTEM AND DATA ACQUISITION

### 2.1 System description and layout

The Multipack is integrated R744 parallel compression system with expansion work recovery through Multi Ejector Solution™, providing: refrigeration, space heating and cooling, and hot water production as shown in Figure 1. The space cooling and heating is by two direct CO<sub>2</sub> rooftop air handling units. Three compression groups installed in the pilot. Three compressors for medium temperature level (MT comp), three compressors at Low-Temperature level (LT comp), and four units are dedicated for Air-Conditioning (AC comp) total installed electrical power for compressors and fans is 177 kW (Excluding air handling fans). More details in the system has already been covered in 1st part of the paper. (Minetto 2019)

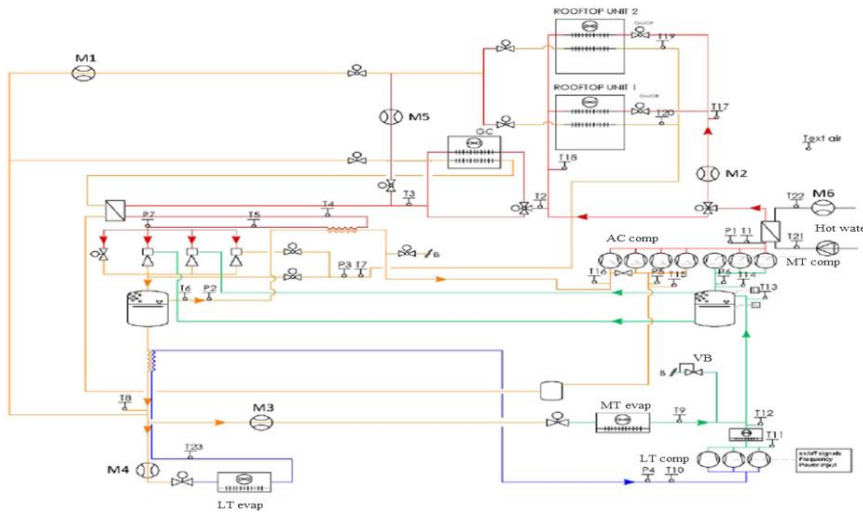

Figure 1 Integrates R744 system layout

### 2.2 Ejectors

There are in total 5 ejector blocks in the system. The liquid ejector (LE) pumps the liquid from suction accumulator at MT level to receiver at IT level. High-pressure lift ejectors (HP) compresses part of the vapor from accumulator at MT level to receiver at IT level & low pressure lift ejectors (LP) that used to retrieve the gas in the outlet of air handling unit back to receiver. One liquid ejector (LE) of type LE600 Danfoss Multi Ejector Solution™ with cartridge capacities of 200 & 400 kg/h, two high-pressure lift ejector (HP) of type HP 3875 Danfoss Multi Ejector Solution™ with cartridge capacities of 125, 250, 500 & 3\*1000 kg/h and two low pressure lift ejector (LP) of type LP 1935 Danfoss Multi Ejector Solution™ with cartridge capacities: 60, 125, 250 & 3\*500 kg/h has been installed in the pilot.

### Ejector control

The high-pressure ejectors (HP) are controlled in a way to support the high-pressure reference at the outlet of the gas cooler. The liquid ejectors (LE) are controlled from the levels of liquid in the suction accumulators. The low-pressure ejector (LP) ejectors are controlled independently with a dedicated controller following a strategy to match the air conditioning cooling demand.

### 3. EJECTORS ENTRAINMENT RATIO

The ejector performance can be evaluated by the ratio of mass flow rate into the suction port to the mass flow rate into the discharge port which is known as the entrainment ratio. Two different methods used to estimate:

1. CO<sub>2</sub> two-phase ejector laboratory data and CFD based reduced-order model
2. Ejector suction and motive nozzle mass flow estimation based on data-driven model

The ejector entrainment ratio is calculated as follows:

$$Ent_{Rat} = \dot{m}_{Suction} / \dot{m}_{Motive} \quad \text{Eq. 1}$$

#### CO<sub>2</sub> two-phase ejector laboratory data and CFD based RoM

This method based on the reduced-order model for R744 two-phase ejector by Haida et al. (2018) who developed proper orthogonal decomposition (POD) with the radial basis function (RBF) to evaluate the motive nozzle operation from 70 bar to 100 bar pressure range. This is later transferred into an easy to use object-oriented R744 two-phase ejector reduced-order model (in form of a dll function) by Haida et al. (2018, 2019, and 2020) that is used to calculate entrainment ratio given a certain set of inputs. The variables required include:

For motive nozzle: motive pressure [Pa], motive temperature [K], motive specific enthalpy [J/kg]

For suction port: suction pressure [Pa], suction temperature [K], suction specific enthalpy [J/kg]

For ejector outlet: outlet pressure [Pa]

#### Ejector suction and motive nozzle mass flow estimation based on data-driven model

Data-driven method has been utilized in the first part "PERFORMANCE OF INTEGRATED R744-PACKS PART 1 - COMPRESSOR MASS FLOW ESTIMATION BASED ON DATA-DRIVEN MODELS USING ANALYTICAL METHODS AND ACTUAL FIELD MEASUREMENTS" to get an accurate estimation of mass flow from compressors, this allows to solve the mass balance over the ejector ports and calculate the entrainment ratio based on the field measurements.

For the weeks with HP ejector and/or LE ejector in operation, the mass for MT cannot be directly measured so the MT compression group mass flow is estimated from the data-driven model for MT compressors.

Since there is no dedicated mass flow meter installed for IT compressors mass flow rate, compressor mass flow rate estimator is trained based on MT compressors. This enables the use of all data in disposal i.e. running capacity, pressure, temperature and power consumption, to be used in other systems.

As indicated in Part 1, the data-driven model is a grey-box model that utilizes all the relevant data in its disposal to estimate the mass flow rate. This data include: pressure, temperature, running capacity, power consumption, mass flow estimation from analytical methods, i.e. energy balance using constant heat loss, volumetric displacement, and compressor manufacturer polynomials.

The mass flow through high pressure valve (HPV) is calculated through a model from CoolSelector 2<sup>®</sup>, that receives as input opening degree of the valve, pressure ratios and inlet temperature and returns an estimation of mass flow through the valve.

#### 4. DATA-DRIVEN METHOD ENTRAINMENT RATIO ESTIMATION

The test on the pilot for ejector performance evaluation has been running for 8 weeks during summer with various modes; modes are based on various configurations of with or without ejectors of each type. The ejectors layout and mass flow layout is depicted in Figure 2 and the operation modes are as follows:

- Week 30 AC LP on + HP off + ALC off (From: July 25 Thursday 17h00 To: August 1 Thursday 17h30)  
This is the flooded mode (ALC OFF) in which MT suction setpoint is also changed from -4 to -8 and the only ejectors running are LP ejector dedicated to AC operation.
- Week 32 AC DX on + HP off + ALC on (From: August 8 Thursday 16h30 To: August 15 Thursday 17h15) in which the only ejector running is liquid ejector
- Week 34 AC DX on + HP on + ALC off (From: August 22 Thursday 16h30 To: August 29 Thursday 17h30) in which the only ejectors running are HP ejectors.

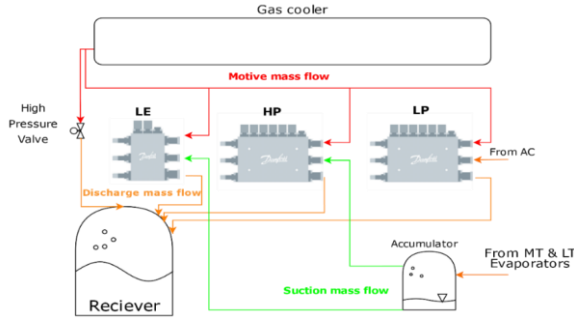

Figure 2 - Ejector layout

##### Low pressure lift ejector (LP): Week 30

Data from week 30 has been used to compare the data-driven model calculation with RoM outputs for LP ejectors. In this mode, the mass flow from gas cooler goes partially through LP ejector and the rest passes through HPV to enable smooth control of receiver pressure.

The mass flow in the motive and suction nozzle is calculated by:

$$m_{Motive} = m_{MT_{comp}} + m_{IT_{comp}} - m_{HPV} \quad \text{Eq. 2}$$

$$m_{Suction} = m_{AC_{Evap}} \quad \text{Eq. 3}$$

##### Liquid ejector (LE): Week 32

Data from week 32 has been used to compare the data-driven model calculation with RoM outputs for LE ejectors. In this week only ejector in the system is liquid ejector and the mass flow out of gas cooler is partially passing through the motive nozzle of the ejector and the rest passes through HPV. The mass flow in the motive and suction nozzle is calculated by:

$$m_{Motive} = m_{MT_{comp}} + m_{IT_{comp}} - m_{HPV} - m_{AC_{Evap}} \quad \text{Eq. 4}$$

$$m_{Suction} = m_{MT_{Evap}} + m_{LT_{Evap}} - m_{MT_{Comp}} \quad \text{Eq. 5}$$

### High pressure ejector (HP): Week 34

Data from week 34 has been used to compare the data-driven model calculation with RoM outputs for HP ejectors. During this operation the only ejectors are HP ejectors and the HPV is fully closed. The mass flow in the motive nozzle is calculated by Equation 6 and 7. The entrainment ratio is calculated using Equation 1 (Figure 5).

$$m_{Motive} = m_{MT_{Comp}} + m_{LT_{Comp}} - m_{AC_{Evap}} \quad \text{Eq. 6}$$

$$m_{Suction} = m_{MT_{Evap}} + m_{LT_{Evap}} - m_{MT_{Comp}} \quad \text{Eq. 7}$$

## 5. RESULTS AND DISCUSSION

As it can be seen from Figure 3-5, there are differences between the entrainment ratio from the RoM estimated value and the data-driven method. The discrepancies are different from one ejector type to other. Below the sources of errors are discussed for each ejector group and common sources of errors:

### General sources of errors

The data-driven model is expected to have below 3% error on the mean value of the individual compressors mass flow rates but in specific data points up to 14% error is observed, for e.g. the MT compressors. This can have an error propagation effect on the calculations.

The RoM model has been developed on lab data and CFD simulations on each single cartridge and it does not account for the influences of the parallel operation integration in a block nor the effect of pressure losses inside the ejector block. The model has been developed for a specific operation envelop, (inlet outlet conditions) and outside the envelop the validity of the model is unknown. Potential inaccuracies also exist for both lab measurement and CFD simulation that can lead to propagation to more errors; the RoM model is expected to have error in the range of 5-10%.

### 5.1. LP ejector

The entrainment ratio of the LP ejector is calculated by Equation 1-3. Figure 3 shows the results from data-driven method compared with RoM. (Hunter 2007)

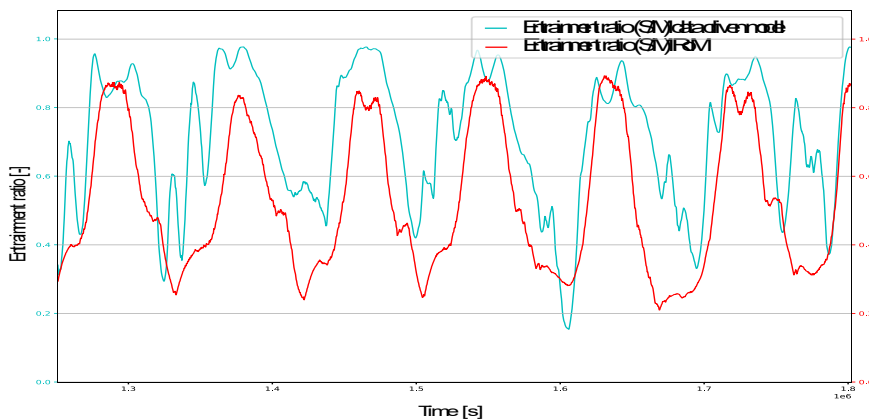
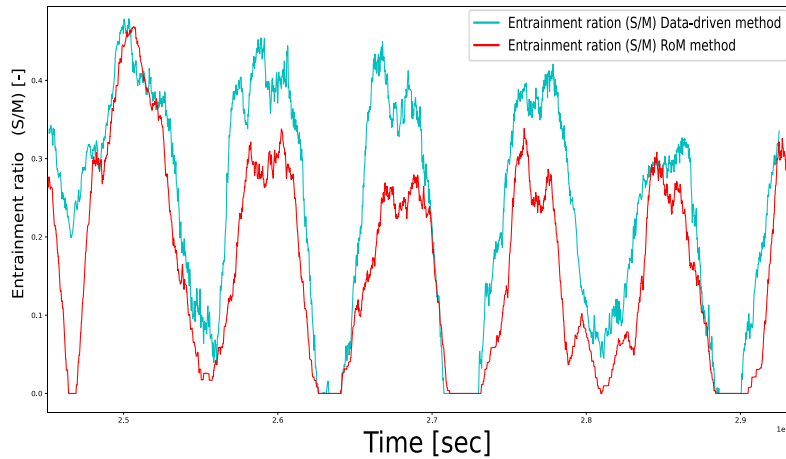

**Figure 3 – LP ejector entrainment ratio**

Both models follow the same trend. However, the entrainment ratio calculated by the data-driven model shows higher values compared to the RoM valued. The deviation is most likely arising due to overestimation of mass flow in HPV model. The mass flow rate estimation for HPV is based on estimation from opening degree of the valve utilizing a tuned semiempirical model and it is expected that the error is below 10%.

### Liquid ejector

The entrainment ratio calculated by Eq. 1, 4 and 5 that is depicted on figure 4.

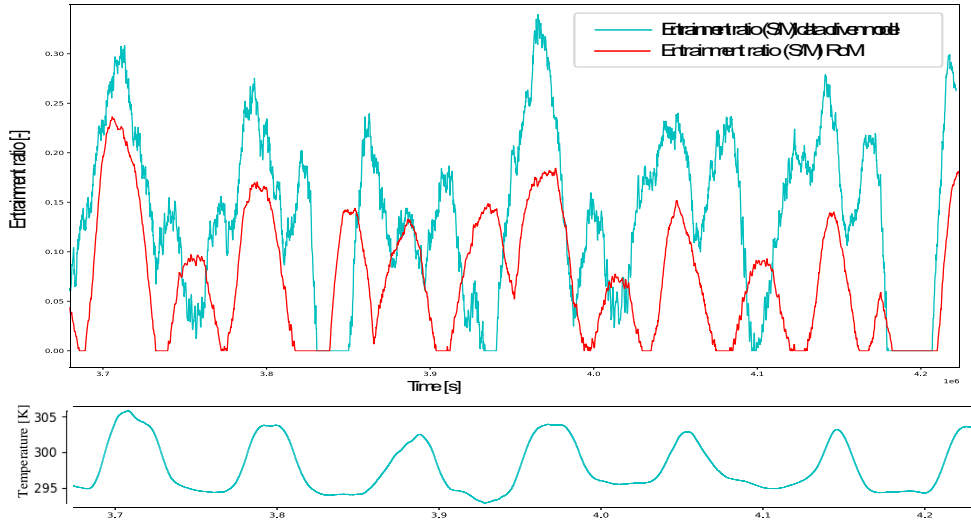

**Figure 4 - Liquid ejector entrainment ratio(up) & the liquid level sensor (On/Off of LE operation) 180 sample moving average(down)**

Due to the complications and constraint with the RoM model for comparison the CFD data from RoM has been excluded in this case. The conducted comparison indicates that both models are predicting a similar entrainment ratio. Both models are following a similar trend, however with smaller gradients for the RoM. The level sensor in the suction accumulator is included in the RoM model calculation to account for the On/Off operation of liquid ejector.

### HP ejector

The entrainment ratio then calculated as before by (Eq. 1, 6 and 7) that is depicted on Figure 5.



**Figure 5 - HP ejector entrainment ratio(up) and gas cooler outlet temperature (3 hour moving average) plot(down)**

For the HP ejector the deviation between the RoM and data-driven model is substantial. One explanation is that the ejector suction superheat exceeds the operation envelope of the RoM causing major error in calculations of the entrainment ratio. Considering the day and night operations, it is expected to have less motive massflow during night, however, the RoM model shows some peaks over night operation as indicated by the gas cooler outlet temperature in figure 5 that cannot be justified with the low load of the system during night. Data-driven model appears to give more realistic estimation both on quantity and on trends of variation.

## 6. CONCLUSIONS

Data-driven model can be utilized as a complementary tool for performance estimation of components especially for the cases with missing direct measurements. However, model training is essential to minimize errors and it requires analysis of the existing uncertainties. Three different ejector blocks were analysed leading to the following conclusions: i) both RoM and Data driven model are in good agreement for the LP ejector. ii) The trend in both RoM and data-driven show a good match specially away from the daily maximum values iii) There is not always a correlation between the two models for HP ejectors, and RoM is operating out of the operation envelope so the validity can not be verified due to more than 15K of superheat at the secondary side.

Analysing the data, the authors believe that data-driven method is giving better indication of system real behaviour based on the expected outcome from system operation (Day/night operation and entrainment ratio values).

## ACKNOWLEDGEMENTS

MultiPACK is a European project funded under the Horizon 2020 Research and Innovation Programme, project number 723137.

