

18th European Conference
The Latest Technology in Refrigeration and Air Conditioning
Milan, 6-7 June 2019

The MultiPACK project: installation and monitoring of integrated commercial refrigeration systems in South Europe

AUTHORS

Silvia Minetto* ⁽¹⁾, Giacomo Tosato⁽¹⁾, Armin Hafner ⁽²⁾,

⁽¹⁾ National Research Council, Construction Technologies Institute, Corso Stati Uniti 4, 35127 Padova (Italy)

⁽²⁾ Norwegian University of Science and Technology, Department of Energy and Process Engineering, Kolbjørn Hejes vei 1 D, 7491 Trondheim (Norway)

* corresponding author: silvia.minetto@itc.cnr.it

ABSTRACT

The EU project MultiPACK aims at building up confidence for standardised integrated cooling & heating packages installed in high energy demanding buildings by demonstrating their technical feasibility, reliability and serviceability together with energy performances. To this aim, six remotely controlled and monitored demonstration sites at several South-European locations at energy demanding end-users are utilised. Amongst them, three supermarkets located in Italy and Portugal were installed and are now monitored. The units are intended to provide refrigeration, heating and air conditioning and they include state-of-the-art technology for CO₂, i.e. ejectors for both vapour compression and liquid recirculation and parallel compression. The real performance of the packs providing refrigeration and space air condition are measured, reported and discussed.

INTRODUCTION

“CO₂ only” solutions currently represent viable and sustainable candidates in commercial refrigeration. According to De Oña et al, 2017, it is expected that these units will be 25.000 in 2020 and 55.000 in 2025 all over Europe.

In the last years, the challenge was to make “CO₂ only” vapor-compression units sustainable on a global perspective including warm regions. Many technical solutions, including parallel compression and expansion work recovery by means of two-phase ejectors, together with improved control of evaporators allowing for wet expansion, are now successfully proposed in the market.

Considering the high specific energy demand of food retail stores, integrated CO₂ systems providing refrigeration, heating and space cooling have been made available. Thus allowing for the use of only one system, based on the natural working fluid CO₂. These systems have proved to be cost and performance competitive, as demonstrated by Karampour and Sawalha (2018).

In general terms, the adoption and the management of new systems in an efficient way, require awareness raising, interdisciplinary knowledge and confidence building, as widely demonstrated by the EU project SuperSmart.

The EU project MultiPACK started in 2016, with the aim of demonstrating the availability, efficiency, competitiveness, reliability of integrated systems for supermarkets. In particular, CO₂ systems including multiejector blocks for expansion work recovery, parallel compression, and evaporator overfeeding are addressed. These units can supply the entire

18th European Conference

The Latest Technology in Refrigeration and Air Conditioning

Milan, 6-7 June 2019

energy demand of the food retail stores, i.e. refrigeration, heating and space cooling and sanitary hot water production.

All MultiPACK systems are fully equipped with measuring instruments, for pressure, temperature, refrigerant mass flow rates and compressor input power, thus allowing for operations monitoring and performances measurement.

In the following sections, two MultiPACK systems, commissioned in Central Italy and Portugal in respectively in summer and winter of 2018, are introduced. The system layouts are illustrated and the overall operation and performance data are presented.

THE MULTIPACK UNIT IN CENTRAL ITALY

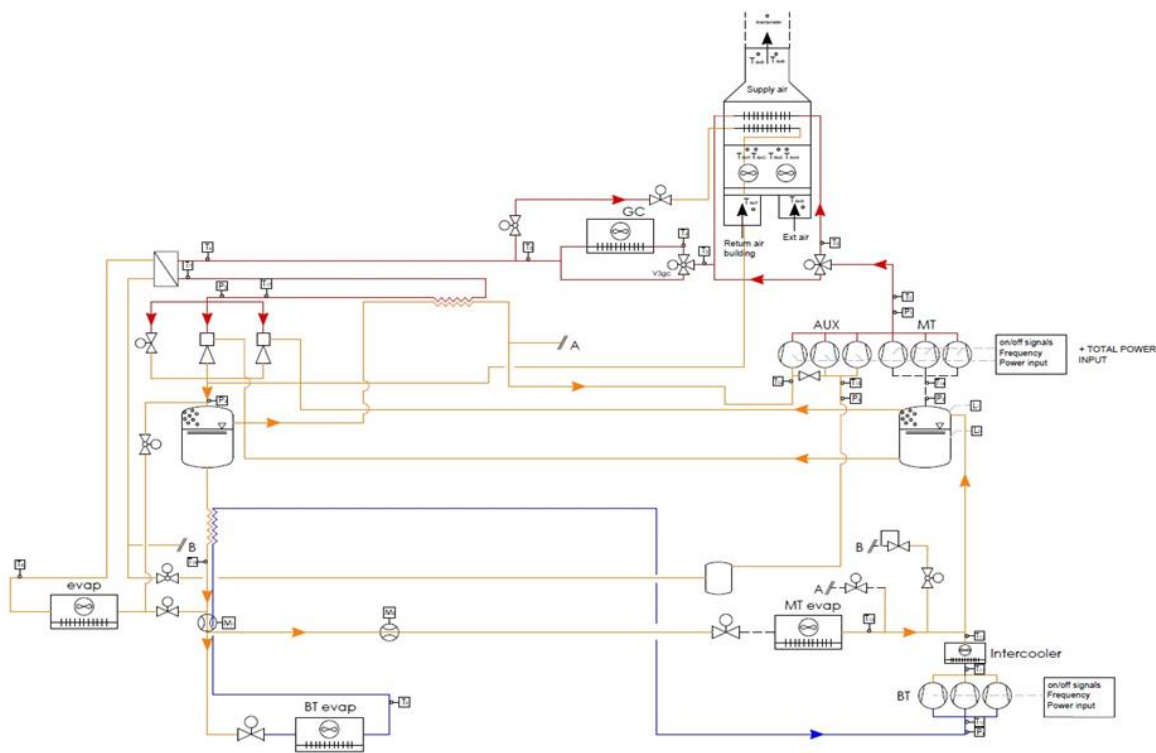

Fig. 1 MultiPACK site lay-out, Central Italy

The overall system layout is presented in Fig. 1. The unit is based on a booster concept with parallel compression and expansion work recovery by means of ejectors for both vapour pre-compression and liquid recirculation. Semi-hermetic compressors are installed, three compressors for each suction pressure level. For each suction group, one out of the three compressors is inverter driven to allow a smoother capacity modulation. The unit delivers the heating demand and the cooling loads of the supermarket by means of an Air Handling Unit AHU. The CO₂ directly flows through the heating and cooling coils of the AHU. In winter time, a three-way valve deviates CO₂ to the AHU coil if requested by the building temperature control device; in this case the high side pressure is elevated. If the heating demand exceeds the heat recovered from the refrigeration system, the heat pump mode is activated. In this case liquid from the receiver is supplied towards the external evaporator. The dedicated auxiliary compressors supporting the heat pump mode can work independently from other auxiliary compressor maintaining the pressure level in the

18th European Conference

The Latest Technology in Refrigeration and Air Conditioning

Milan, 6-7 June 2019

separator, i.e. removing the flash gas and vapour supplied via the ejector from the MT receiver.

In summertime, the AHU cooling coil is fed with two-phase refrigerant expanded through the electronic expansion valve, which is thermostatically controlled. Post-heating after dehumidification is also provided in the AHU by high pressure CO₂ in summertime.

A liquid separator is located downstream of the multiejectors. It enables to manage charge variations in the circuit and provides sufficient liquid head to circulate CO₂ into the two refrigeration lines. In case of non-superheated operation of some MT evaporators, due to the adopted Electronic Expansion Valve EEV control, the liquid accumulated in the suction liquid receiver is pumped back to the separator by liquid ejectors.

Commercial type NTC 10 kΩ sensors and piezoresistive pressure transmitters are used to monitor the operating conditions. In order to evaluate the total electric power input, three-phase electric power meters are located before each compressors rack, i.e. to the Low Temperature (P_{LT}), Medium Temperature (P_{MT}), and Auxiliary (P_{AUX}) compressors. The status of every single compressor and the inverter frequency are also recorded. The total power input to the system, including auxiliaries (fans, pumps, valve motors) is monitored.

Two Coriolis mass flow meters (M) are located in the liquid lines, the first ($M1$) one measures both MT and LT CO₂ mass flow rates, the second one ($M2$) is dedicated to MT flow rates.

On the AHU side, eight temperature and relative humidity sensors are installed to measure enthalpy differences before and after the coils, together with building return air and external air temperature and humidity. A hot wire anemometer is installed on the main air duct, to measure air velocity of the entire air volume flow, so it is possible to calculate the total cooling and heating capacity provided by the MultiPACK unit.

Overall results from the site are summarised in Table 1; winter conditions are available from the field, with heating on, when the shop is open, and heating is off during the night.

COP has been calculated considering only power input to compressors ($COP_{tot, compr}$) and total power input to the unit (COP_{tot} , which include auxiliaries power consumption). The

Load Ratio ($LR = \frac{Q_{MT}}{Q_{LT}}$) and the heating load ratio ($LR_H = \frac{Q_{heating}}{Q_{LT} + Q_{MT}}$) have been detailed as

well, as they are needed to interpret and benchmark the overall COP results

THE MULTIPACK UNIT IN PORTUGAL

The system overall layout is presented in Fig. 2. The MultiPACK system is based on a booster concept with parallel compression and expansion work recovery by ejectors for both vapour pre-compression and liquid recirculation.

Semi-hermetic compressors are installed, three compressors for both MT and LT suction groups and four compressors for the Auxiliary compression suction group. For each suction group, one compressor is inverter driven to allow a smoother capacity modulation. The unit also delivers the entire heating and cooling loads of the supermarket by means of two air handling units AHU. CO₂ directly flows through the heating and cooling coils of the AHU. If requested by the building temperature control unit, in winter time a three-way valve distributes the hot CO₂ to the AHU's coils, consequently the high-pressure level is increased. If the heating demand exceeds the heat recovered from the refrigeration system, the heat pump mode is activated. In heat pump mode, liquid from the separator is distributed to the external evaporator. The dedicated auxiliary compressors supporting the heat pump mode can work independently from auxiliary compressor removing flash gas, due to the integrated solenoid valve separating the suction group.

18th European Conference

The Latest Technology in Refrigeration and Air Conditioning

Milan, 6-7 June 2019

In summer time, the AHU's cooling coils can be fed in two-different ways: the first one is the same as in the MultiPACK unit in Central Italy, i.e. the refrigerant expands from the high-pressure side directly into the coils. In the second mode, the coils can be fed taking the liquid directly from the liquid receiver, due to the integration of the AC ejectors. In this case, the ejector recirculates the liquid from the tank recovering the energy from the high pressure expanded gas. So, it is possible to work in both ways and eventually evaluate the benefit deriving from AC ejector mode. Post heating after dehumidification is also possible in summer.

The MultiPACK unit provides domestic hot water when requested from the building. The DHW heat exchanger is placed downstream of the discharge manifold of the MT and Auxiliary compressors. A three-way valve can direct to the hot CO₂ gas into the heat recovery, i.e. the DHW heat exchanger or simply bypass it when it is not in operation. Vapor- and liquid ejectors are present to compress the vapor from the suction liquid receiver to the liquid separator, and to return the accumulated liquid working fluid when cabinets are working in non-superheated mode.

Table 1: overall results from Central Italy and Portugal sites

	Central Italy (Feb 2019) Heating on	Central Italy (Feb 2019) Heating off	Portugal (March 2019) Heating on	Portugal (March 2019) Heating off
Q_{MT} [kW]	29.2	22.6	24.9	35.7
Q_{LT} [kW]	13.4	10.9	6.1	9.8
$Q_{Heating}$ [kW]	25.5	-	24.3	-
$Q_{Cooling}$ [kW]	-	-	-	-
Q_{DHW} [kW]	-	-	0.4	-
$T_{ev MT}$ [°C]	-4.7	-5.0	-5.0	-5.0
$T_{ev LT}$ [°C]	-31.4	-31.1	-31.0	-31.0
HP [bar]	70.0	53.4	79.4	61.2
$COP_{tot, compr}$	3.4	3.9	4.3	3.4
COP_{tot}	3.1	3.2	3.5	2.9
LR	2.2	2.1	4.1	4.6
LR _H	0.6	-	0.8	-

For operation and performance monitoring, there are 24 commercial type NTC 10 kΩ sensors. Pressure is measured with seven commercial type piezoresistive pressure transmitters. To evaluate the total electric power input, three-phase electric power meters are located before each compressors rack to measure the power input to Low Temperature (P_{LT}), Medium Temperature (P_{MT}), and Auxiliary (P_{AUX}) compressors. The status of every single compressor and the inverter frequency are also recorded. The total power input to the system, including auxiliaries (fans, pumps, valve motors) is monitored.

Five Coriolis mass flow rate meters (M) are placed on the liquid lines. The first one ($M1$) measures the liquid mass flow rate coming from the liquid receiver, that feeds the cooling coils of the AHU in AC ejector working mode. The second one ($M2$) measures the hot gas mass flow rate that goes into the two heating coils in heating seasons, while $M3$ and $M4$ measure the CO₂ mass flow rate to the LT and MT lines. $M5$, is used for measuring the

18th European Conference
The Latest Technology in Refrigeration and Air Conditioning
Milan, 6-7 June 2019

refrigerant mass flow rate to the cooling coils before the gas expands, in the back up cooling mode, when the AC ejectors are not in operation.
A magnetic mass flow meter M6 placed on DHW water side to measure the water mass flow rate through the heat exchanger, also two temperature NTC probes are placed before and after the heat exchanger.
Overall results from the MultiPACK unit in Portugal are summarised in Table 1

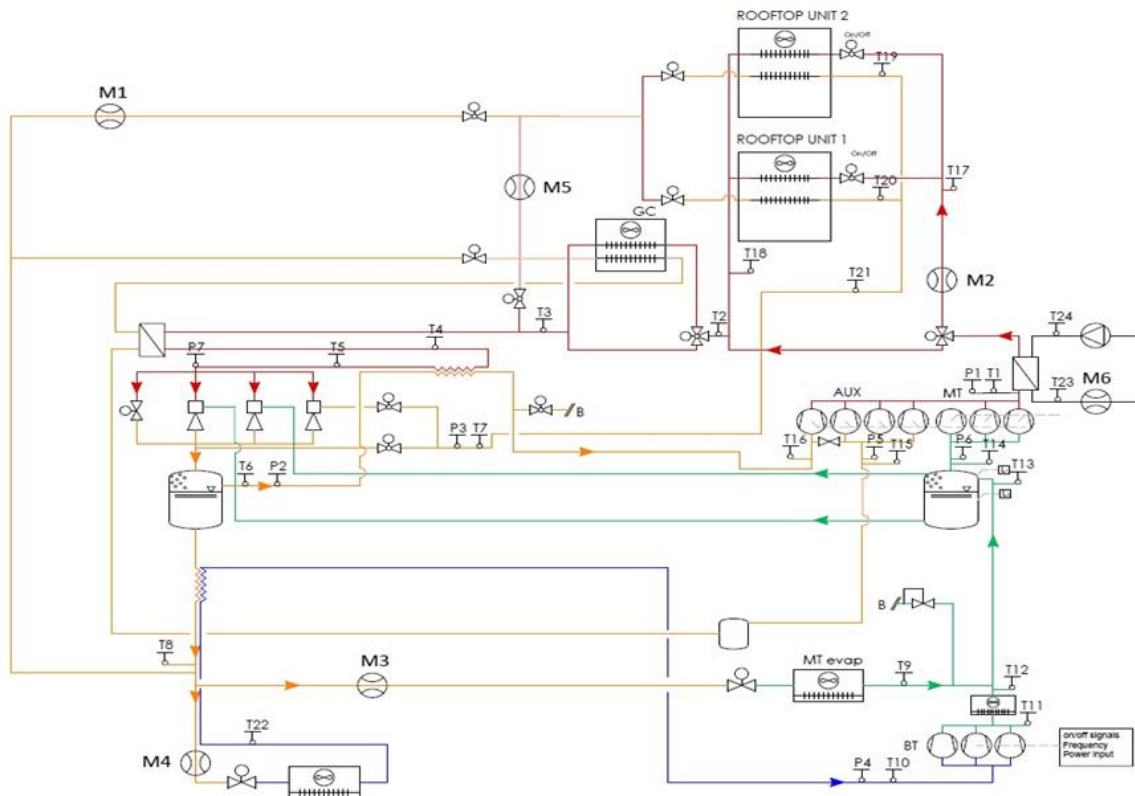

Fig. 2 MultiPACK site layout, Portugal

AKNOWLEDGEMENTS

The activity presented in this manuscript was performed under the MultiPACK project. MultiPACK is a European project funded under the Horizon 2020 Research and Innovation Programme, project number 723137.

REFERENCES

- A. De Oña, A. Gkizelis, K. Skačanová, E Boccabella (2017). Global market and policy trends for CO₂ and Ammonia as natural refrigerants. Ammonia and CO₂ Refrigeration Conference, Ohrid, Republic of Macedonia, IIR.
- Karampour M, Sawalha S., 2018. State-of-the-art integrated CO₂ refrigeration system for supermarkets: A comparative analysis, International Journal of Refrigeration 86: 239–257
- SuperSmart H2020 Innovation Framework Programme, project number 696076. <http://www.supersmart-supermarket.info> (last retrieved 1st February 2019).